

**Customization is available
Products and specifications are
subject to change without notice**

E-P Equipment Co.,LTD

www.ep-ep.com

Let's grow together...

E-P Equipment is a specialized manufacturer of material handling equipment.

China:

E-P EQUIPMENT CO., LTD

① Hangzhou Tiantang Development Zone
No.308 Shiqiao Road, Hangzhou, China

② Da Song Nan Meng, Ying County, Ningbo, China

Tel: 86-571-87219297/87219221/87219203

Fax: 86-571-87219218/87219150

Email: info@ep-ep.com

USA:

E-P EQUIPMENT, USA CORP.

1865 E.Main St.
Suite F, Duncan, SC 29334

Tel: 1-864-486-8774

Fax: 1-864-486-8779

Toll Free: 866-373-8722

E-mail: info@ep-ep.com

Japan:

E-P EQUIPMENT JAPAN

#1052-16-10 Hirao, Inagi-shi
Tokyo 206-0823 Japan

Tel: 81-42-3506422

Fax:81-42-3506423

E-mail:ep-japan@ep-ep.com

Korea:

E-P EQUIPMENT KOREA

1058-Ra Dong, Buck Yi-Dong,
Ilsan/Gu, Koyang/Shi, Kyunggi/Du,
Korea

Tel: 82-31-9254100

Fax:82-31-9254102

E-mail:ep@ep-ep.co.kr



Material Handling Solution

www.ep-ep.com

Material Handling Equipment

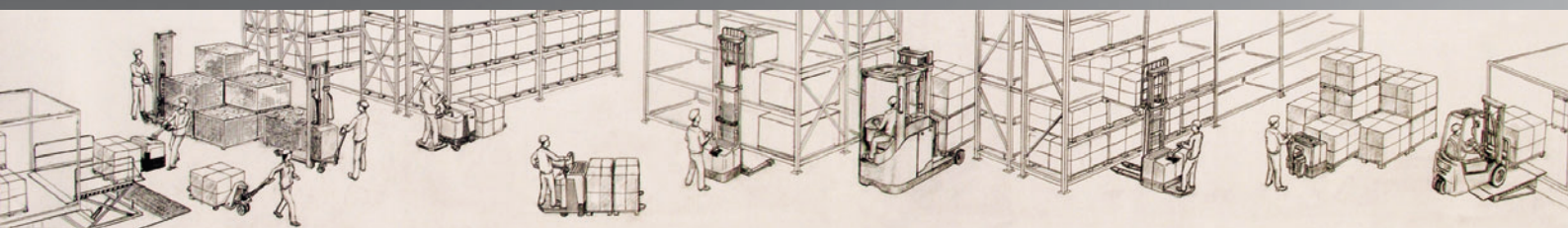

Let's grow together

ISO9001

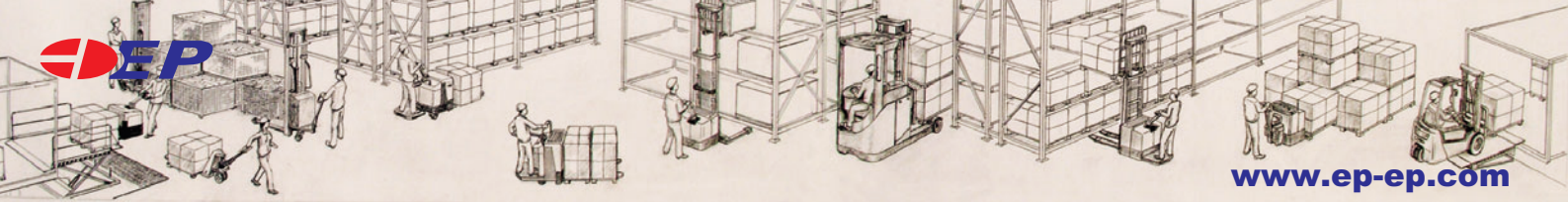

Since 1983, E-P began to produce hydraulic pump and cylinder of forklift and Engineering Machine, Now E-P Equipment is a specialized manufacturer of Material Handling Equipment for the world-wide market.

After 20 years of development, E-P has grown into a manufacturer that can supply a global range of material handling equipments. Do you stack, lift or move goods? If so, count on E-P to provide you with what you need.

We supply various material handling equipments such as hand pallet trucks, electric pallet stackers, electric pallet trucks, hydraulic cylinders, forklifts and etc. Are you looking for One-stop shopping of Material Handling Equipment? E-P offers you the best solution by being the No.1 manufacturer of electric series pallet trucks in China. When E-P began updating its electric series products, its target was upgrading into the worldwide market. So, E-P Electric Trucks are now world class in quality, excellence & appearance with a competitive price and a 100% service guarantee.

E-P Equipment is not and will never be a “ just sales only ” type of company, we are a “ customer friendly ” brand marketing manufacturer that cares about the happiness of each user. After 20 years in sales, E-P is familiar with most of the worldwide market and set branches in USA/Canada, Japan, Europe, UK, Australia, The Middle East, South Africa and some south-east Asian countries such as Korea and Thailand. All E-P branches are specialized in material handling equipment so you know you can count on their knowledge and expertise.

Born in “ world factory ” China, E-P Equipment manufactures and supplies various service. This is what keeps E-P on the competitive edge regarding after sales maintenance and to help the buyer save money with replacement parts. E-P has technological advances and state of the art design along with world class production to satisfy customer requirements.

E-P is great at developing new products according to market requirements, based on this, our sales has more than surpassed our expectations. So with this, we would like to say for those who are considering E-P as your choice, just use our motto “ Let’s Grow Together ” and grow together.

Mr. Wang wenping, Manage Director

Mr. John He, General Manager

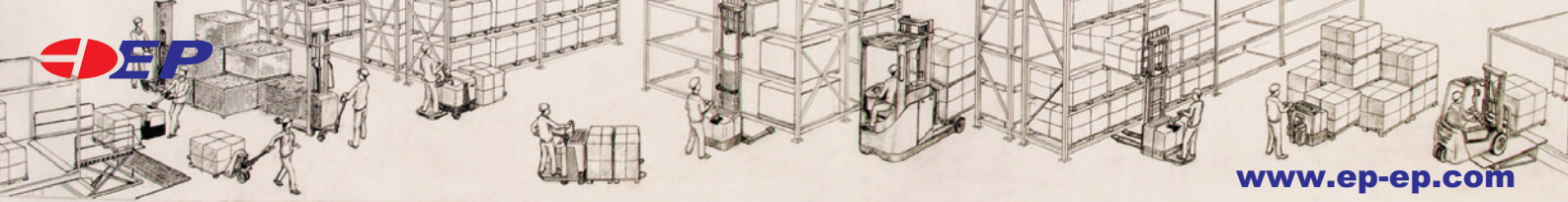

CONTENTS

1. Hand Pallet Truck.....	1
2. High Lift Hand Pallet Truck.....	7
3. Lift Table	11
4. Platform Stacker	13
5. Manual Stacker	15
6. Manual Drum Stacker	17
7. Fork Lift Jack	18
8. Electric Manual Stacker.....	19

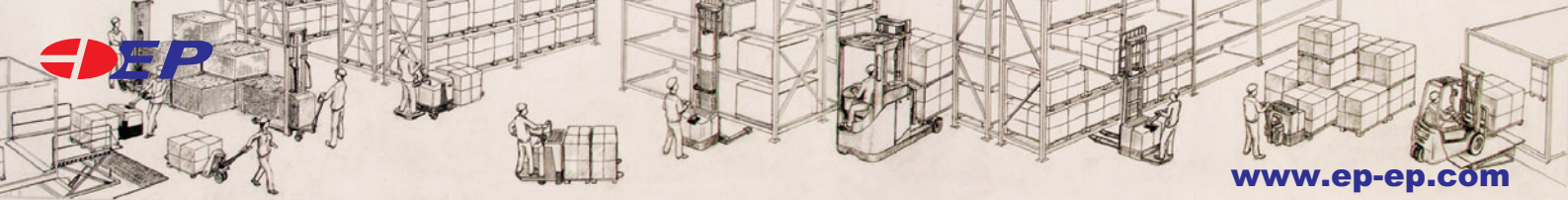

Hand Pallet Truck

Technical Performance

HIGH RELIABLE/LONG LIFE PUMP



- One piece tough nodular cast iron pump body with special infiltration process
- Hard chrome plated Ram and Piston
- World level quality Seals
- CNC machining



SPECIAL DESIGN VALVE

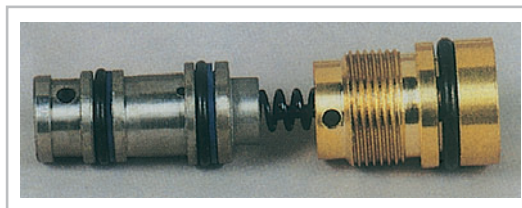

- Lowering quickly at unload and slower at load
- Complete Valve, Quick and easy to replace



- High frequency induction hardness treatment on shaft
- Bushing
- Grease Nipples (Option)

STRONG/HIGH ACCURATE FORK FRAME

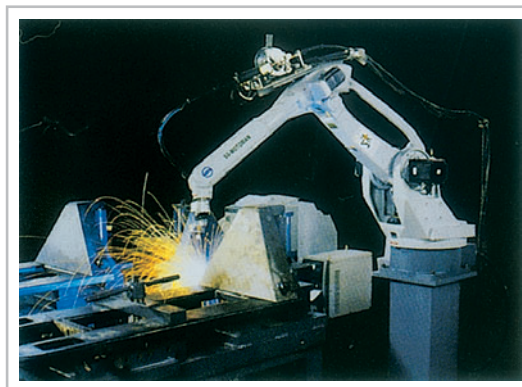

- High quality welded by robot
- Constructed by heavy duty steel
- High tensile forged lifting link
- Solid push rod
- Steel Ball Spray Treatment to deep rustless
- 3 coats stove paint

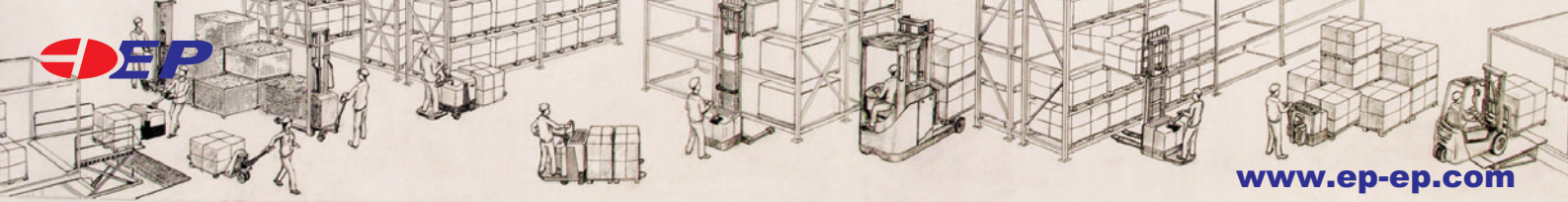

Specification

Model	Number of Load Wheel (pcs)	Kinds of Load Wheel	Kinds of Steering Wheel	Kinds of Handle
II	SINGLE	NY PU	NY PU-IRON	HANDLE-II-R HANDLE-III
III	TANDEM	VO	PU-ALUMINIUM RB	HANDLE-III-R

Handles & Wheels



HANDLE-II-R

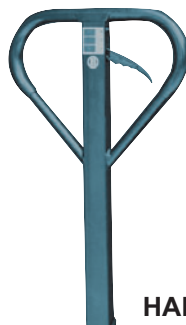

HANDLE-III-R



HANDLE-III



VO



RB



PU-ALUMINIUM



PU



PU-IRON



NY



NY



VO

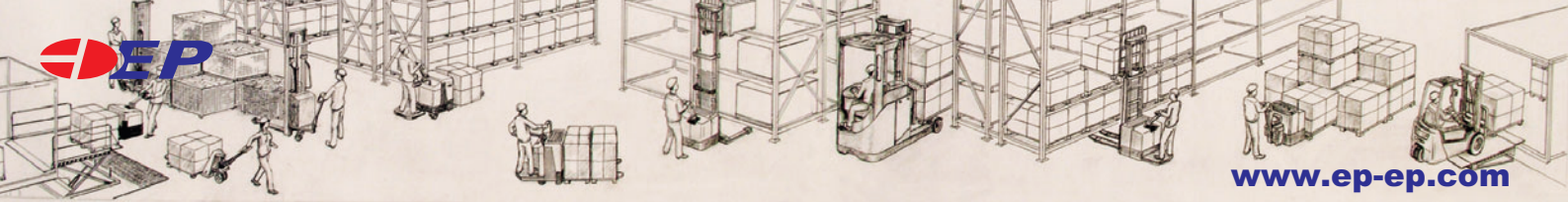

www.ep-ep.com

Hand Pallet Truck

Specifications



CBY23-II



CBY23-II



CBY23-III



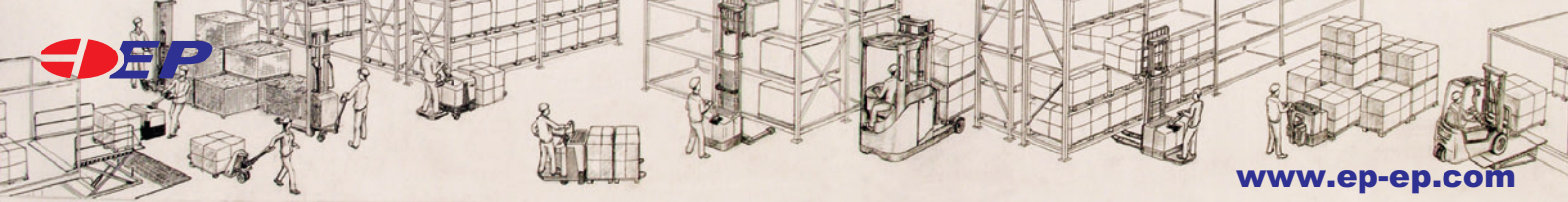

Hand Pallet Truck

Specifications

Model		CBY23 - II / III	
Capacity (standard fork size)		2000kg	2500kg
Standard fork length	L1	1150/1220mm	
Special fork length	L1	800/900/950/1000/1300/1500/1800/2000mm	
Overall fork width	W1	540/685mm	
Lowered height of single load wheel	H1	74mm	
Lowered height of tandem load wheel	H1	85mm	
Lifting height	H2	>110mm	
Fork width	W2	160mm	
Distance from load wheel to end of fork	L3	115mm	
Distance	L2	360mm	
Total height of truck	H0	1200mm	
Load wheel size		Ø 78*70 / Ø 73*93mm	
Steering wheel size	A	Ø 180mm	
Self weight		75kg	85kg
Wooden pallet package size of 6 units		2300*550*750mm / 2300*700*730mm	
20' container can load	units	180/144units	

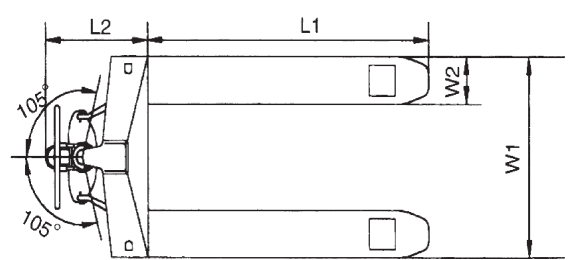
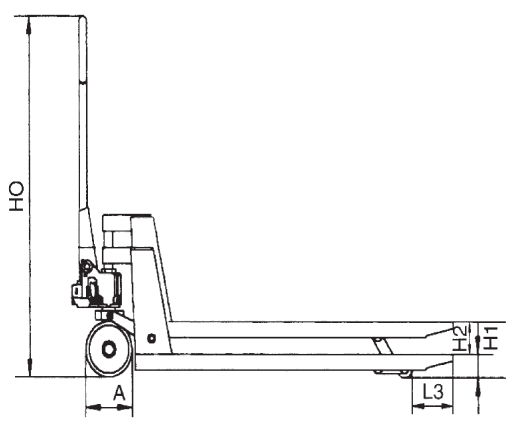

Products and specifications are subject to change without notice.



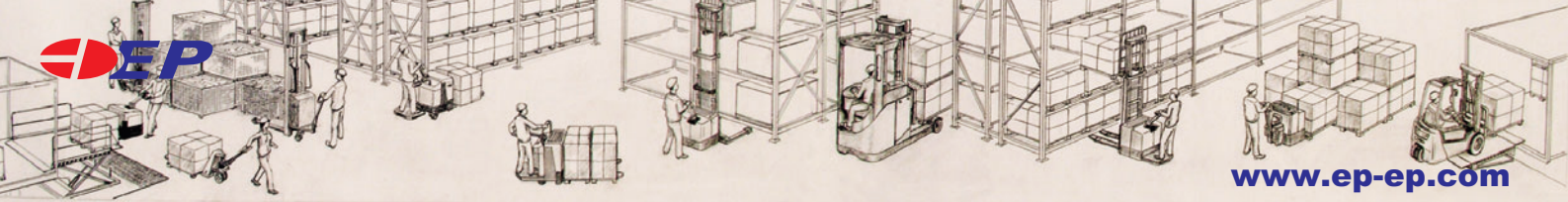

Hand Pallet Truck



• Galvanized & Stainless



• With brake



• With scale



• Low profile

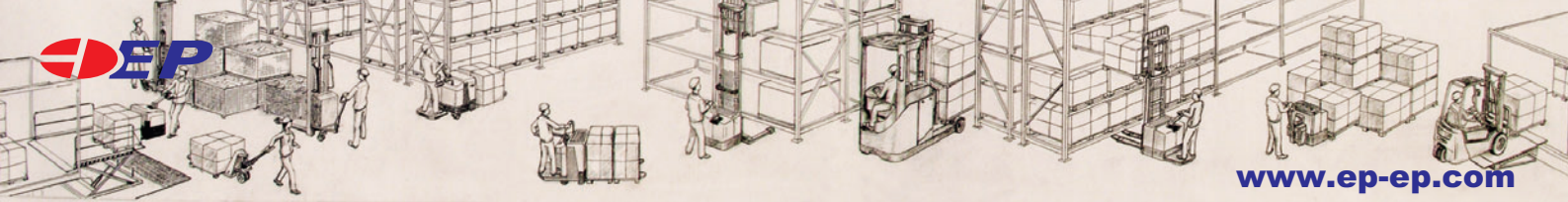

Hand Pallet Truck

Specifications

Model	EP20S	EP25G	EP15L	EP20L	EP20ES	EP25HB
Specifications	Stainless	Galvanized	Low profile	Low profile	With scale	With brake
Capacity (standard fork size)	2000kg	2500kg	1500kg	2000kg	2000kg	2500kg
Overall fork width	540mm,685mm					
standard fork length	1150,1220mm					
Lowered height	85mm	85/74mm	51mm	51mm	85mm	85mm
Lifting height	200mm					
Load wheel	Single, Tandem					
	Nylon,PU,steel					
Steering wheel	NY	NY	NY/PU	NY/PU	NY/PU/RB	NY/PU/RB
Self weight	80kg	80kg	80kg	80kg	110kg	80kg

- Safe and easy operation, no oil leakage
- 3-position control: up, neutral, down
- Equipped with overload valve
- Special size requirements available

Products and specifications are subject to change without notice.



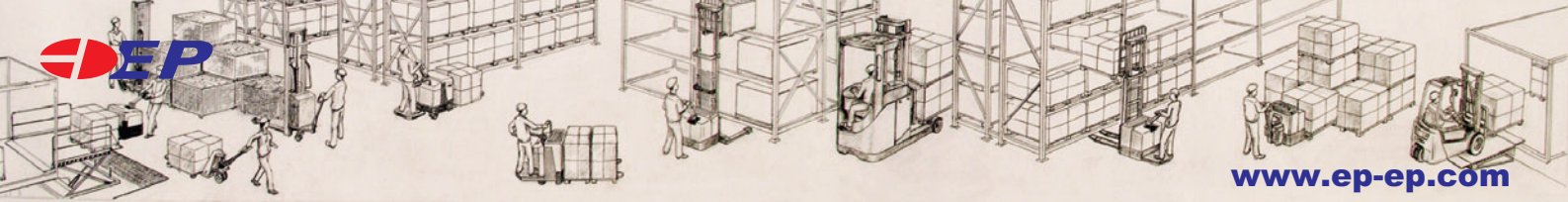

High Lift Hand Pallet Truck

Specifications

Model		HLT1000-S	
Capacity	Kg	1000	1000
Lowered height	mm	85	85
Lifting height	mm	800	800
Times of lifting to top		≤ 78	≤ 78
Overall fork width	mm	540	680
Fork length	mm	1150	1150
Size of front wheel	mm	Ø 75*50	Ø 75*50
Size of rear wheel	mm	Ø 180*50	Ø 180*50
Net weight	Kg	128	133
Gross weight/Net weight of wooden pallet package for 4 units	Kg	545/512	567/532
Dimension of wooden pallet package for 4 units	mm	2000*600*1110	2000*740*1110
20' container load	units	72	64

- One stage cylinder provide extra reliable hydraulic system.

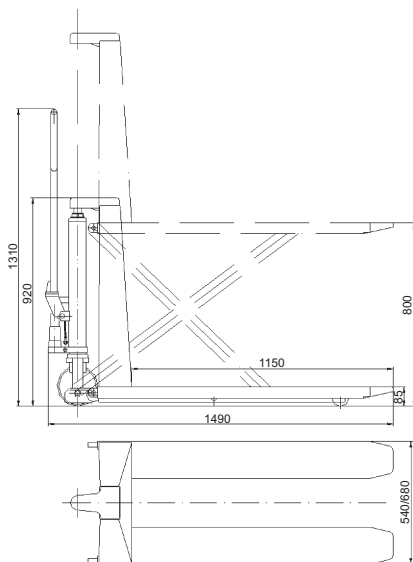

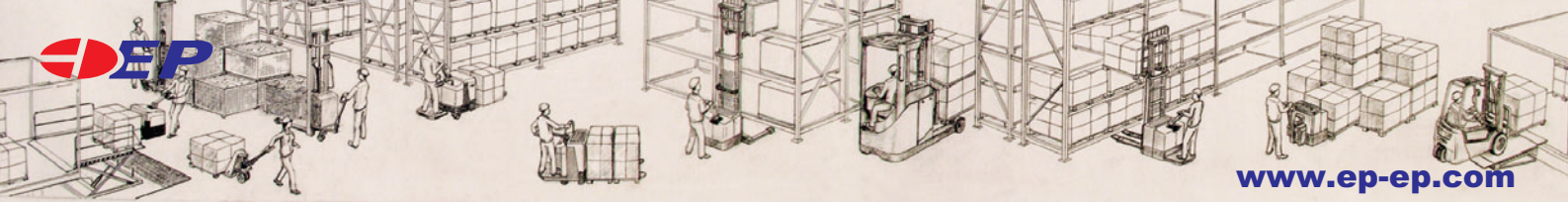

High Lift Hand Pallet Truck

Specifications

Model		HLT1000-D		HLT1500-D	
Capacity (first stage)	kgs	1000		1500	
Lowered height	mm	85 ± 2			
Lifting height	mm	800			
Fork length	mm	1140		1100	
Overall fork width	mm	520	680	520	680
Single fork width	mm	162			
Size of front wheel	mm	Ø75*50			
Size of rear wheel	mm	Ø150*40		Ø150*40	
Times of lifting to top		≤ 63			
Overall truck length	mm	1500			
Overall truck width	mm	535	695	535	695
Overall truck height	mm	1260			
Net weight	kgs	105	112	118	125
Dimension of wooden pallet package for 4 units	mm	1930*580*720	1930*740*720	1930*580*770	1930*740*720
Gross weight of wooden pallet package for 4 units	kgs	450	485	510	540
20' container load	units	120	96	100	96

- Used as both a work table and pallet truck
- Automatic stabilizer keeps truck stable in high position
- A lock device (patented) on the release lever guarantees safe operation
- Lowering-control-system prevents the truck from causing damage to the load
- Safety-overload-system prevents the truck from being overloaded beyond its rated capacity

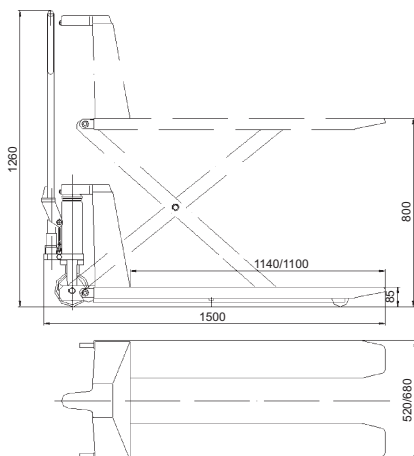

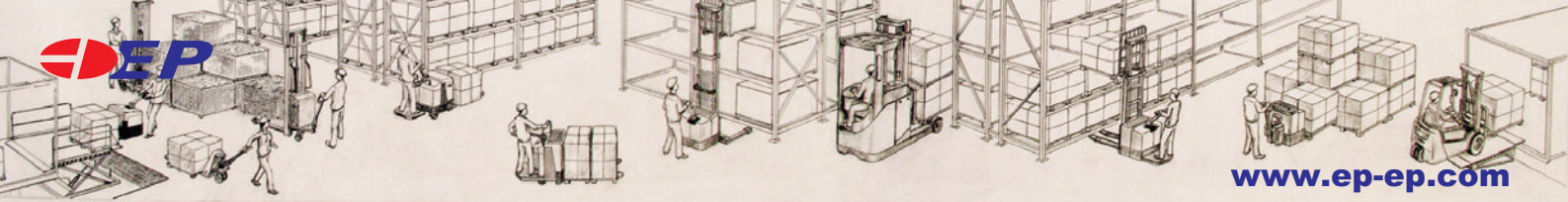

High Lift Hand Pallet Truck

Specifications

Model		EHLT1000-S	
Capacity	Kg	1000	1000
Lowered height	mm	85 ± 2	85 ± 2
Lifting height	mm	800	800
Time of lifting to top (unladen)	sec	≤ 11	≤ 11
Time of lifting to top (laden)	sec	≤ 19	≤ 19
Overall fork width	mm	540	680
Fork length	mm	1150	1150
size of front wheel	mm	Ø 75*50	Ø 75*50
size of rear wheel	mm	Ø 180*50	Ø 180*50
Net weight	Kg	141	146
Dimension of wooden pallet package for 2 units	mm	2240*600*1110	2240*740*1110
Charger		10A/12V	10A/12V
Battery		66AH/12V	66AH/12V

- Used as both a work table and pallet truck
- Automatic stabilizer keeps truck stable in high position
- A lock device (patented) on the release lever guarantees safe operation
- Lowering-control-system prevents the truck from causing damage to the load
- Safety-overload-system prevents the truck from being overloaded beyond its rated capacity

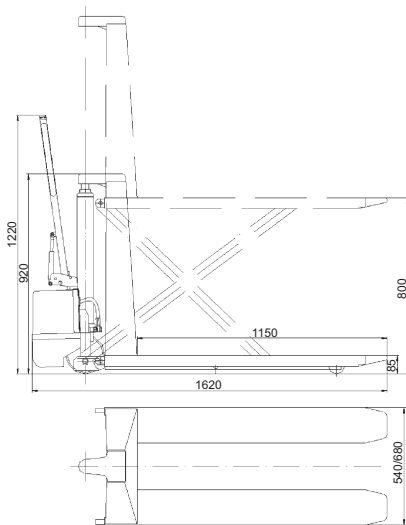

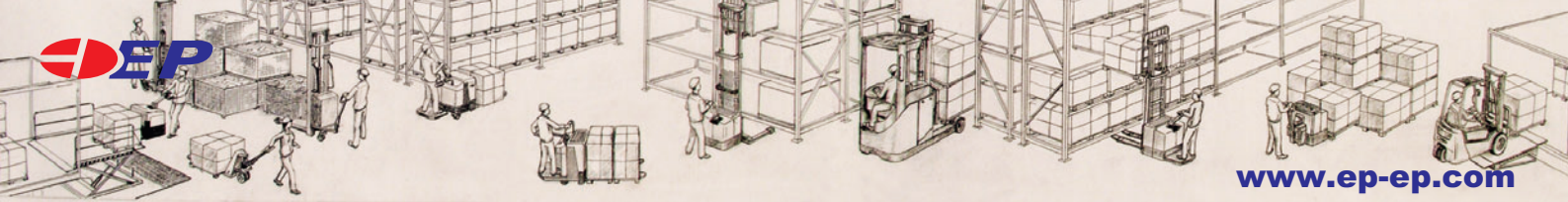

High Lift Hand Pallet Truck

Specifications

Model		EHLT1000-D		EHLT1500-D		
Capacity (first stage)	kgs	1000		1500		
Lowered height	mm	85 ± 2				
Lifting height	mm	800				
Fork length	mm	1140		1100		
Overall fork width	mm	520	680	520	680	
Single fork width	mm	162				
size of front wheel	mm	Ø 75*50				
size of rear wheel	mm	Ø150*40		Ø150*40		
Time of lifting to top	sec	20				
Overall dimension	mm	1600*535*1200	1600*695*1200	1600*535*1200	1600*695*1200	
Service weight	kgs	140	147	149	157	
Dimension of wooden pallet package for 1 unit	mm	1670*600*630	1670*760*630	1670*600*630	1670*760*630	
Gross weight of package for 1 unit with motor box	kgs	165	175	175	185	
Dimension of wooden pallet package for 4 units	mm	1930*580*770	1930*740*720	1930*580*770	1930*740*720	
Gross weight of package for 4 units without motor box	kgs	450	485	510	540	
Dimension of wooden pallet package for motor box	mm	4sets/package 1475*355*955				
Gross weight of wooden pallet package for motor box	kgs	230				
20' container load	1 unit in one package	units	60	42	60	42
	4 units in one package	units	66	72	66	72

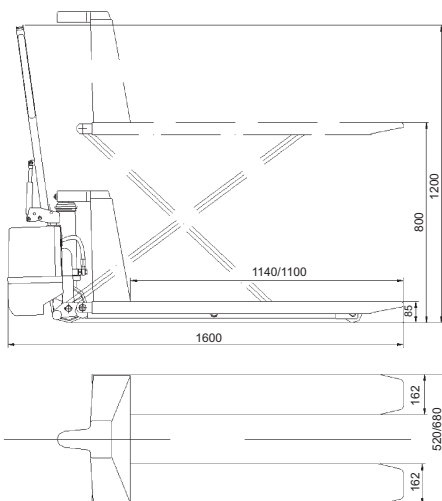

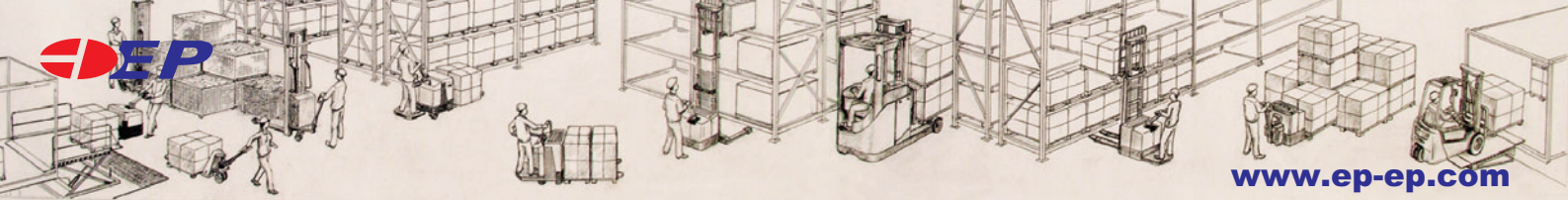

Lift Table Specifications



TF50T



TF15A/30A/50A



TF30B/50B/75B/100B



Type		TF50T
Load Capacity	kg	500
Lowered Height	mm	270
Lifting Height	mm	810
Table Dimension	mm	815*500
Net Weight	kg	81
Packing Dimension	mm	110*520*290
Load in 20' Container	pcs	152

Type		TF15A/30A/50A
Load Capacity	kg	150/300/500
Lowered Height	mm	210/280/280
Lifting Height	mm	720/900/900
Table Dimension	mm	800*450*35
		815*500*50 815*500*50
Net Weight	kg	40/74/82
Packing Dimension	mm	800*470*240
		900*510*310 900*510*310
Load in 20' Container	pcs	280/168/168

Type		TF30B/50B/75B/100B
Load Capacity	kg	300/500/750/1000
Lowered Height	mm	280/280/415/415
Lifting Height	mm	900/900/1000/1000
Table Dimension	mm	815*500*50
		815*500*50
		1000*510*50 1000*510*50
Net Weight	kg	76/84/114/116
Packing Dimension	mm	900*510*290
		900*510*290
		1160*580*430 1160*580*430
Load in 20' Container	pcs	168/168/90/90

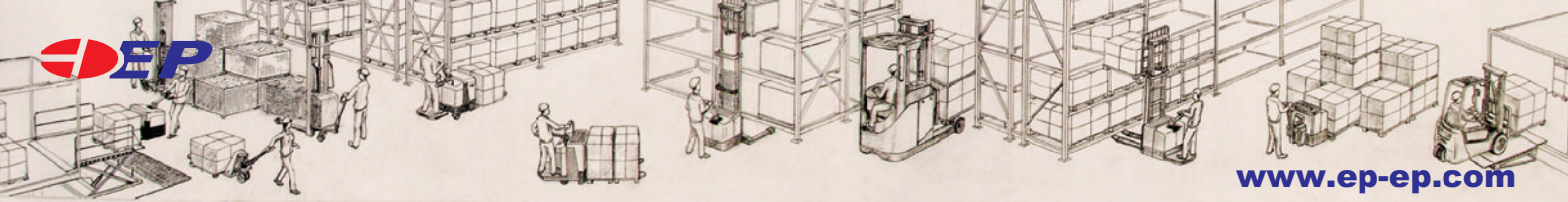

Lift Table

Specifications

Type		TF35SD/50SD/75SD/100SD
Load Capacity	kg	350/500/750/1000
Lowered Height	mm	350/350/430/500
Lifting Height	mm	1300/1300/1500/1700
Table Dimension	mm	905*512*50
		905*512*50
		1200*600*50
		1200*610*50
Net Weight	kg	104/110/150/245
Packing Dimension	mm	1010*530*360
		1010*530*360
		1300*620*456
		1400*620*510
Load in 20' Container	pcs	120/120/52/52

Can be Customized



TF35SD/50SD/75SD/100SD

Type		TF35B
Load Capacity	kg	350
Lowered Height	mm	350
Lifting Height	mm	1300
Table Dimension	mm	905*512*50
Net Weight	kg	108
Packing Dimension	mm	1010*530*360
Load in 20' Container	pcs	120

Can be Customized



TF35B



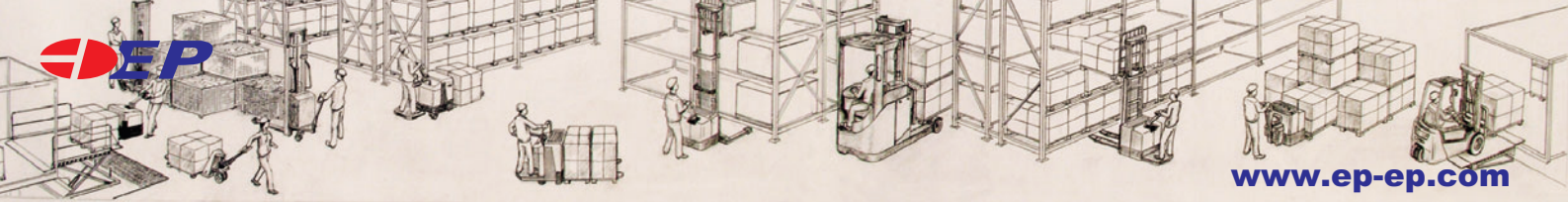

Platform Stacker

Specifications



PFS400

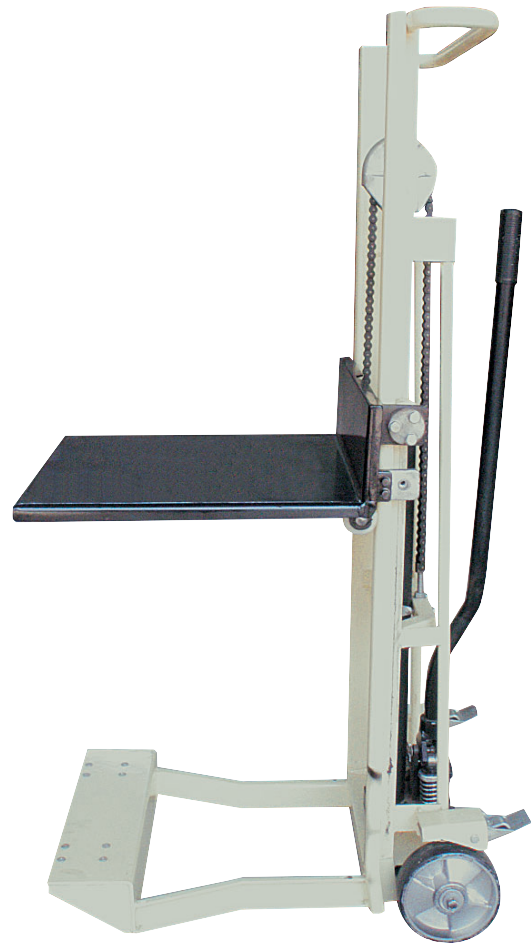

PFS350

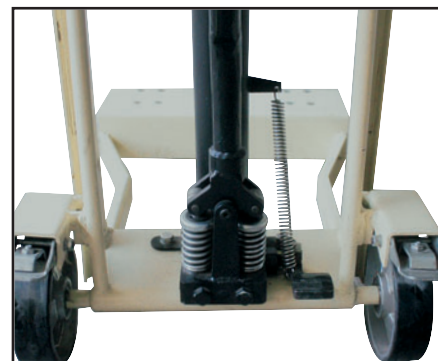

Double Piston Hydraulic Pump

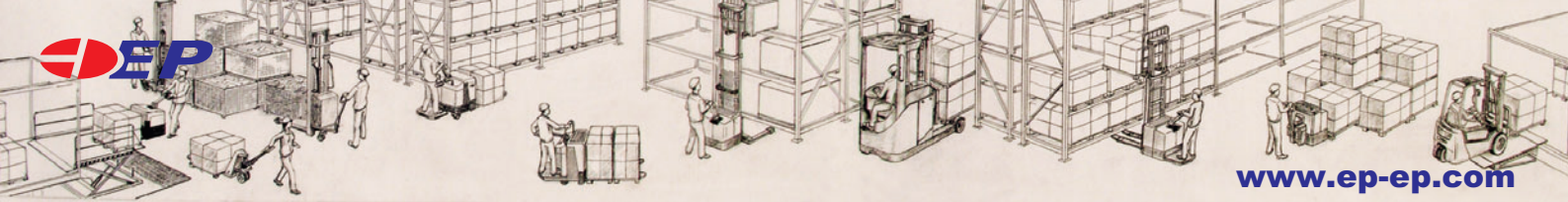

Platform Stacker

Specifications

Model		PFS350
Capacity	kg	350
Lifting height	mm	1370
Lowering height	mm	146
Times of lifting to top		24
Platform dimension (L*W)	mm	560*560
Overall length	mm	798
Overall width	mm	570
Overall height	mm	1556
Self weight	kg	75

- Compact design and very easy to use.
- Operated by hydraulic pump with handle, making lifting effortlessly; also by foot pedal, meeting lowering easily.
- Double piston hydraulic pump to meet the fastest lifting. (PFS350)
- Easily moving around with two universal wheels, to meet stacking needs in a narrow aisle. (PFS400)
- Roller chain with over 5 times capacity yield.
- Different platform dimensions are available.

Model		PFS400
Load capacity	kg	400
Lowered height	mm	90
Lifting height	mm	1100
Length of the fork	mm	610
Table dimension (L*W)	mm	610*570
Overall length	mm	1150
Overall width	mm	1365
Net weight	kg	90
Load in 20' container	pcs	44



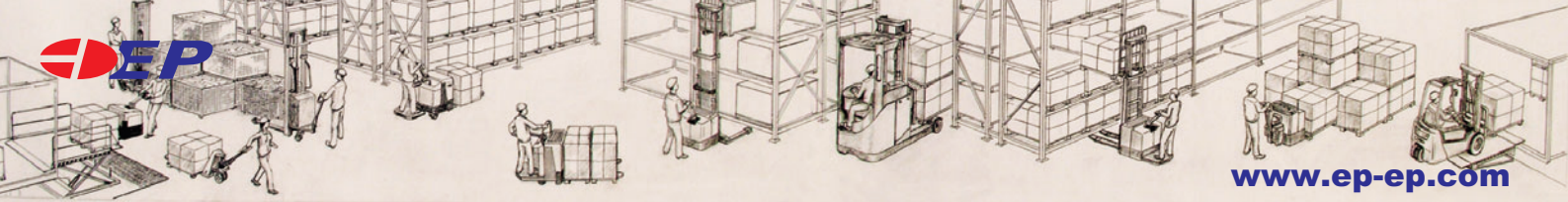

Manual Stacker

Specifications



Double action pump option

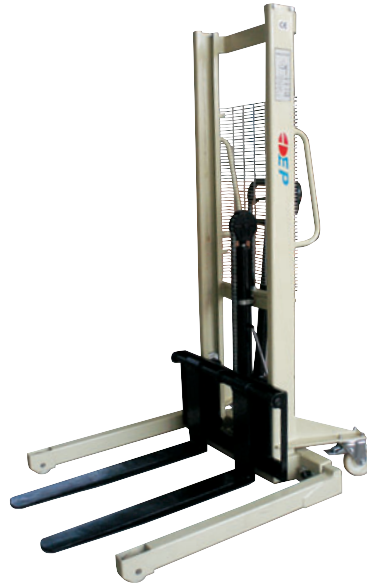

MSA1000/1500



MSE500/1000/1500

- Effortless lifting at an economical price
- This lift is designed to handle skids, pallets, tools and dies, position work, feed machinery, and other handling tasks.
- Units is operated by hydraulic foot pump together with handle, making lifting effortless, also foot pedal or handle lowering valve.
- Hydraulic cylinder with chrome-plated ram, also master fitted with heavy-duty roller bearings, with flow control valve located at base of lift cylinder that regulates lowering speed for safety.
- Steer with rear swivel casters for ease maneuverability, safety screen, foot operated swivel caster parking brake.
- Quick lifting for your choice.
- Wheel brake is standard.
- Roller chain with over 5 times capacity yield.



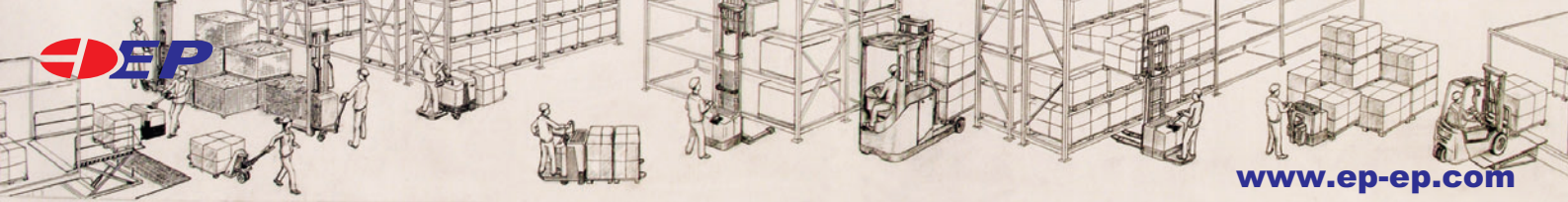

Manual Stacker

Specifications

Model			MSE500		MSE1000 MSA1000		MSE1500 MSA1500	
Lifting height		mm	1600	2500	1600	2500	1600	2500
Capacity		kg	500		1000		1500	
Load center		mm	600		600		600	
Overall height	A Lowered height of fork	mm	2010	1770	2010	1770	2010	1770
	Raised height	mm	2010	2970	2010	2970	2010	2970
Times of lifting to top	Standard		98-105	150-160	98-105	150-160	98-105	150-160
	Double pump		60-65	100-110	60-65	100-110	60-65	100-110
	Quick lift pump		55-60		55-60			
Overall fork width/length (MSE500/1000/1500)		mm	560*1150		560*1150		560*1150	
Overall legs width (MSA1000/1500)		mm			1067		1067	
Fork width		mm	160		160		160	
Self weight		kg	160	280	210	310	246	330
Dimension of wheel	Steering wheel	mm	Ø 150		Ø 150		Ø 150	
	Front wheel	mm	Ø 80		Ø 80		Ø 80	

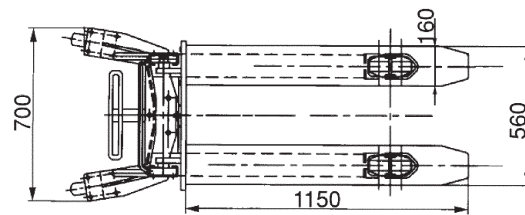
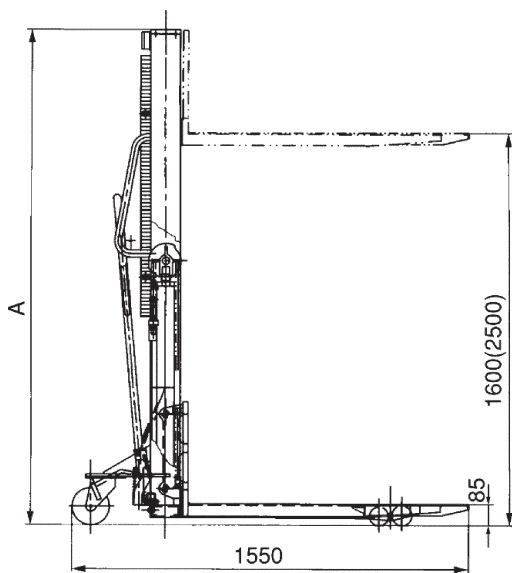

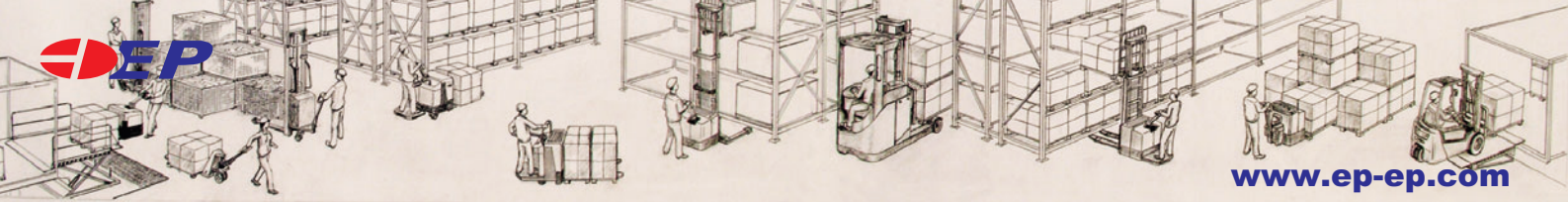

Manual Drum Stacker

Specifications

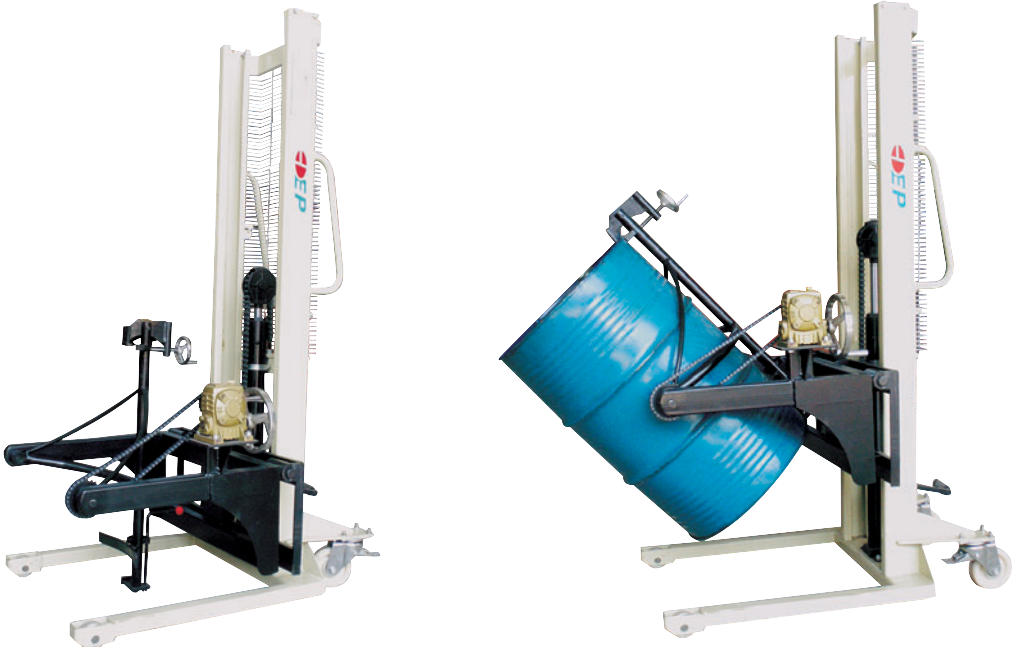

MDS350 (350KG CAPACITY)

See reference specification on page 16 manual stacker

Type		COY-A
Capacity	kg	300
Lifting Height	mm	≤ 200
Dimension (L*W*H)	mm	1000*880*1000
Load wheel size	mm	180*50
Steering wheel size	mm	125*40
Service Weight	kg	40



COY-A (300KG CAPACITY)



Fork Lift Jack

Specifications

Model		FJ4000
Capacity	kg	4000
Lowered height	mm	65
Lifting height	mm	406
Times of lifting to top		45
Size of rear wheel	mm	Ø 78*42
Handle length	mm	700
Net weight	kg	33
Weight with package	kg	35
Overall dimension	mm	670*220*408
20' container load	pcs	256

Model		FJ5000	
Position		Low position	High position
Capacity	kg	4000	5000
Lowered height	mm	65	340
Lifting height	mm	425	724
Net weight	kg	45	
Weight with package	kg	47	
Overall dimension	mm	680*210*340	
20' container load	pcs	360	



FJ4000

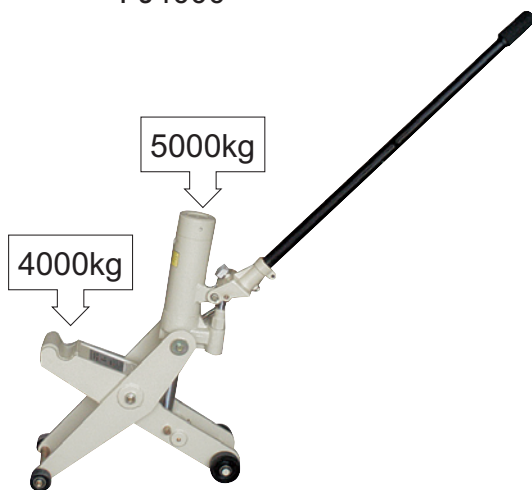
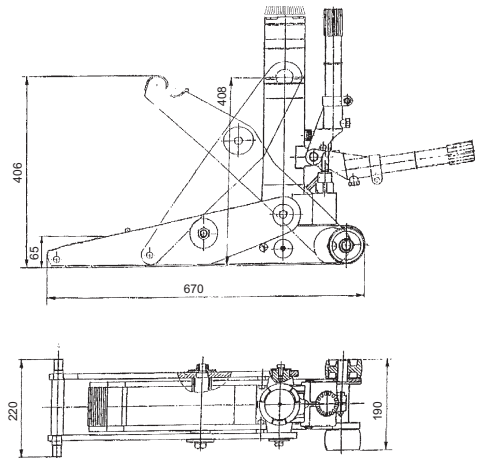

FJ5000

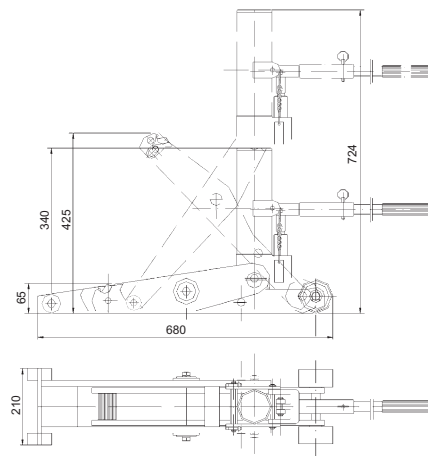

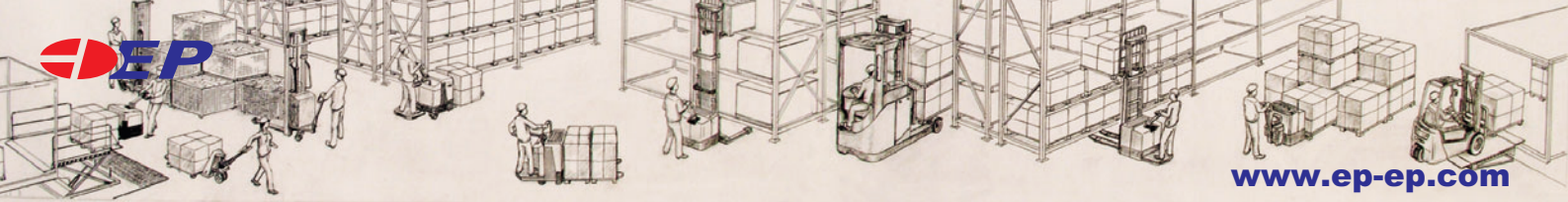

Electric Manual Stacker

Specifications



EMS-E650



EMS-A1000/1500



EMS-E1000/1500

Electric manual stacker is designed for the in-between handling application that require power lift, but do not require drive.

- Moves large bulky crates and skids easily
- Intergrated hydraulic system (pump, valve) with heavy-duty 12volt battery with built-in 12-amp fully automatic battery charge and heavy-duty plug in cord.
- With flow control valve located at base of lift cylinder that regulates lowering speed for safety.
- Mast are fitted with heavy-duty roller bearing.
- Heavy-duty chain with over 5 times capacity
- With drivers safety screen.
- Floor lock brake that keeps stacker steady when lowering or lifting a load also for driver safety.
- Battery capacity indictor

Electric Manual Stacker

Specifications

Model			EMS-E650	EMS-E1000 EMS-A1000			EMS-E1500 EMS-A1500			
Lifting height	A	mm	1600	1600	2500	3000	1600	2500	3000	
Capacity		kg	650	1000			1500			
Load center		mm	600	600			600			
Overall height	B	Lowered height of fork	mm	2010	2010	1770	2010	2010	1770	2010
		Raised height	mm	2010	2010	2970	2970	2010	2970	2970
Lifting speed	Unladen	mm/s	64-107	64-107	83-125	86-120	64-107	83-125	86-120	
	Laden	mm/s	64-107	64-107	83-125	25-120	64-107	83-125	25-120	
Lowering speed	Unladen	mm/s	controllable	controllable			controllable			
	Laden	mm/s								
Overall forks width / length (EMS-E650/1000/1500)		D*G	mm	560*1150			560*1150			
Overall legs width (EMS-A1000/1500)			mm	1067			1067			
Overall length	C	mm	1600	1600			1600			
Fork width	E	mm	121	160			160			
Self weight		kg	236	320	370	400	330	428	487	
Diameter of wheel	Steering wheel	mm	Ø 200	Ø 200 / Ø 180			Ø 200 / Ø 180			
	front wheel	mm	Ø 80	Ø 80			Ø 80			
Battery			12V/80AH	12V/120AH			12V/120AH			
Charger			220V/12A	220V/12A			220V/12A			

